





# The Story of Everly

Crafted a Vision for Affordable Luxury and Sustainability

## The Vision

Everly was born from a dream to create beautifully designed, high-quality furniture that is accessible. This dream combined a love for craftsmanship with a commitment to sustainability, aiming to make luxury both affordable and environmentally friendly.

## The Experience

Designed for those who crave affordable luxury and thoughtful design, Everly offers furniture that embodies elegance, functionality, and environmental consciousness. Every piece is a testament to exquisite craftsmanship and responsible living, using eco-friendly materials and processes to build a sustainable future.

## Embracing Technology

To enhance the customer experience, Everly embraced the power of AI and technology. Their innovative platform makes it easy to browse a diverse catalogue, customize pieces and create a cozy, stylish living space.

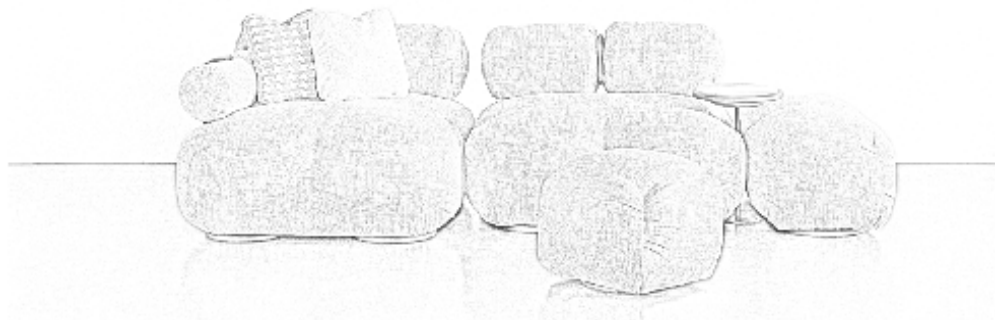

## TABLE OF CONTENTS

<b>Introduction</b>	<b>3 - 7</b>
Story	3
<b>Blend &amp; Bloom</b>	<b>8 - 39</b>
Indoor fabrics theme	8 - 27
Outdoor fabrics theme	28 - 39
<b>Furniture</b>	<b>40 - 95</b>
Sofas	40 - 53
Outdoor Sofas	54 - 67
In & Outdoor Tables	68 - 83
Chairs	84 - 95
<b>Rugs</b>	<b>96 - 101</b>
Rugs	96 - 101
<b>Accessories</b>	<b>104 - 107</b>
Cushions: Box Finish	104 - 107





“Creativity is the greatest expression of liberty.”

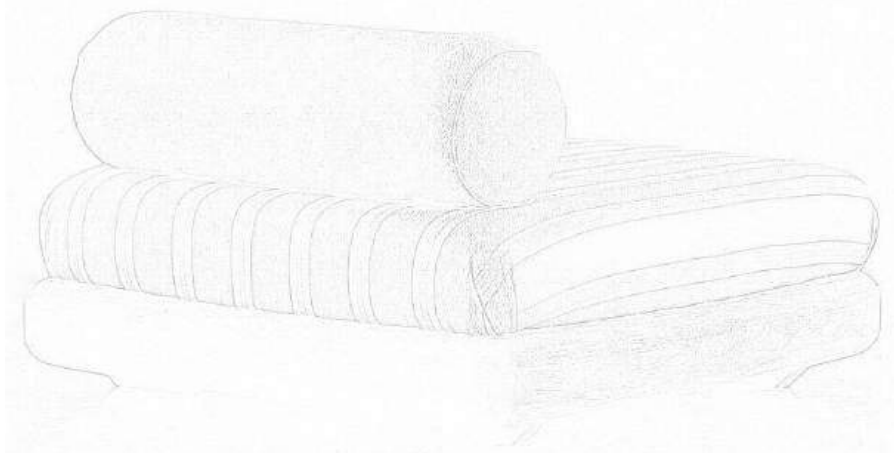







# SOFAS

---



# THE MOONSTONE | Sofa

Karine's inspiration came from the natural elegance of moonstones, their soft glow and smooth curves mirrored in the design. She envisioned a sofa that exuded a sense of tranquility and sophistication, much like the gemstone itself. The plissé fabric was chosen for its textured beauty and ability to create soft, flowing lines, adding a tactile dimension to the design.

The Moonstone sofa would be as good as only foam structure, eliminating the need for wood and reducing its environmental footprint.

"I wanted to create something unique, a piece that stands out yet feels inviting and adaptable."

The design is made to be modular, comprising six distinct elements that could be combined in endless configurations: one long chair module, one petite chair module, a duo chair module, a long pouf, a petite pouf, and a square pouf. This flexibility allowed the sofa to fit seamlessly into any space, whether a cozy apartment or a spacious living room.

Choose for backrest and legs:



Material: Wood  
Color: Dark Walnut



Material: Wood  
Color: Light Oak



Material: Wood  
Color: Black Oak







# THE MOONSTONE | Sofa

## 6 Modular Elements

1. The Moonstone Sofa  
Longchair element 100W x 120L x 67H (CM)  
Armrest left or right side

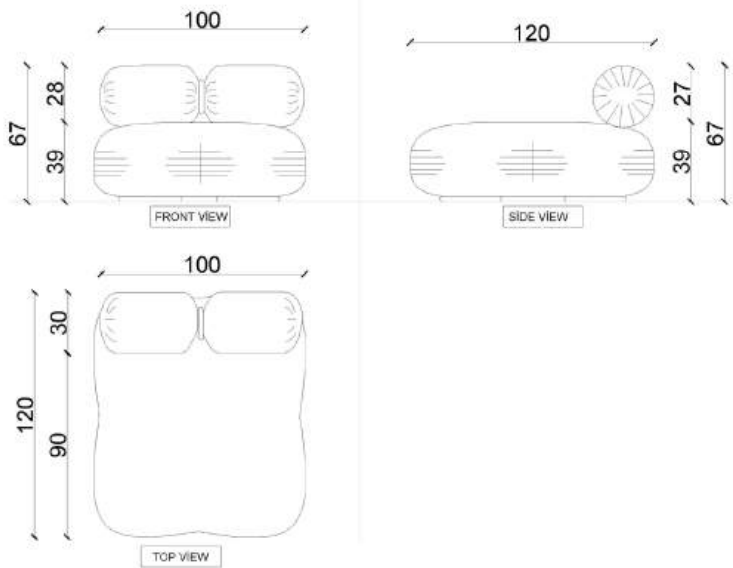

2. The Moonstone Sofa  
Petitechair element 100W x 100L x 67H (CM)

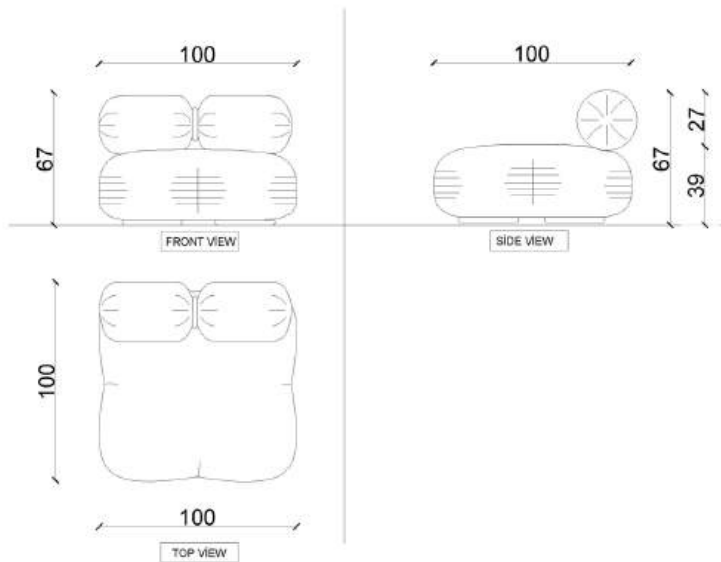



# THE MOONSTONE | Sofa

## 6 Modular Elements

3. The Moonstone Sofa  
Longpouf element 50W x 120L x 39H (CM)

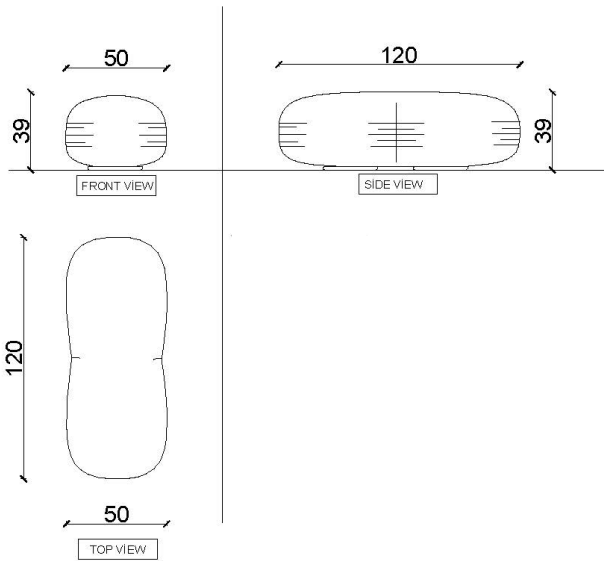

4. The Moonstone Sofa  
Petitepouf element 50W x 100L x 39H (CM)

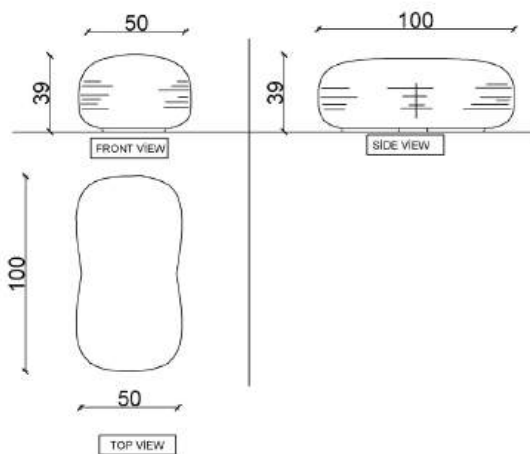

# THE MOONSTONE | Sofa

## 6 Modular Elements

5. The Moonstone Sofa  
 Square pouf element 50W x 50L x 39H (CM)

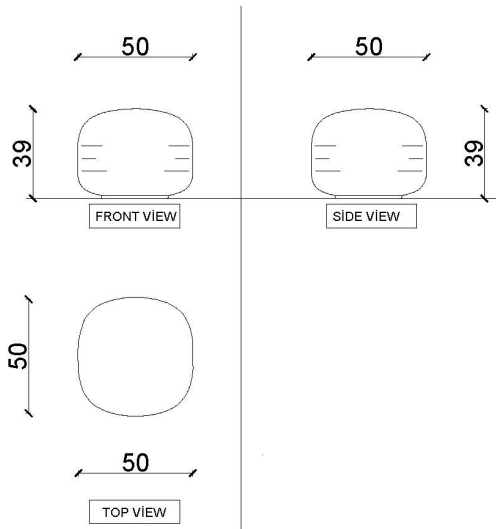

6. The Moonstone Sofa  
 Duochair element 120W x 100L x 67H (CM)  
 Movable backrest

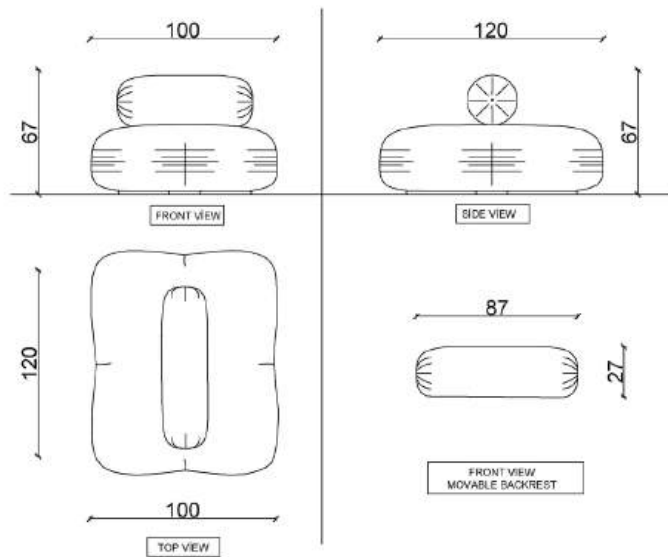

# THE MOONSTONE | Sofa configurations

Longchair (with armrest left) + Petite Element + Petite Element  
Fabric: Ore Forest Green



Longchair (with armrest left) + Petite Element + Long Pouf + Square Pouf  
Fabric: Ore Forest Green



# THE MOONSTONE | Sofa configurations

Island setting:  
Longchair (with armrest left) + Petite Element + Petite Element  
Fabric: Ore Forest Green





# OUTDOOR SOFAS



# THE AL FRESCO | Outdoor Sofa

the Al Fresco Sofa is a testament to what can be achieved when creativity meets responsibility. The base gives the sofa a strong foundation, while the soft curves and seating invite you to sit back and unwind. The combination of different fabrics and the innovative use of recycled materials make this sofa both a statement piece and a model of sustainable design.

Every detail, from the rounded edges of the base to the precise stitching of the fabric, has been carefully considered to ensure the highest quality.

The vision of creating comfortable, sustainable, and aesthetically pleasing furniture for outdoor spaces has culminated in the creation of the Al Fresco Sofa.

The design is made to be modular, comprising six distinct elements that could be combined in endless configurations: one long chair module, one petite chair module, a duo chair module, a long pouf, a petite pouf, and a square pouf. This flexibility allowed the sofa to fit seamlessly into any space.

## Choose for base:



Material: Iroko Wood  
Color: Dark Iroko



Material: Iroko Wood  
Color: Light Iroko



Material: Iroko Wood  
Color: Black Iroko









# THE AL FRESCO | Outdoor Sofa

## 6 Modular Elements

1. The Al Fresco Sofa  
Longchair element 100W x 120L x 65H (CM)  
Removable backrest

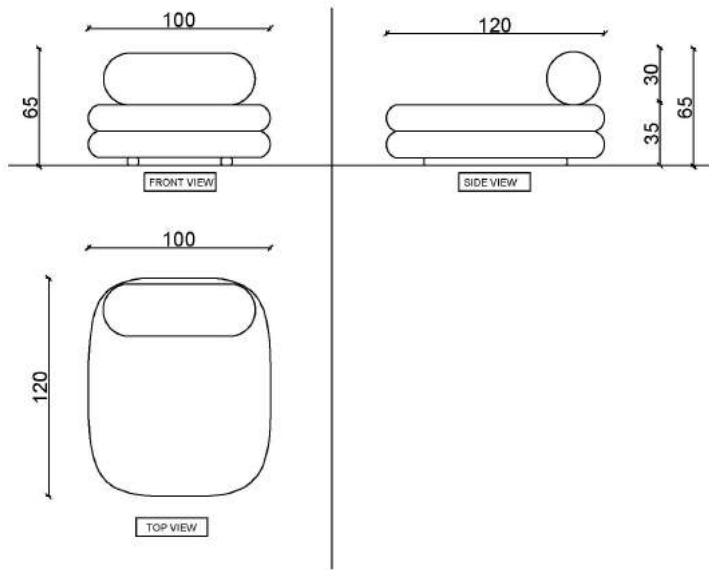

2. The Al Fresco Sofa  
Petitechair element 100W x 100L x 65H (CM)  
Removable backrest

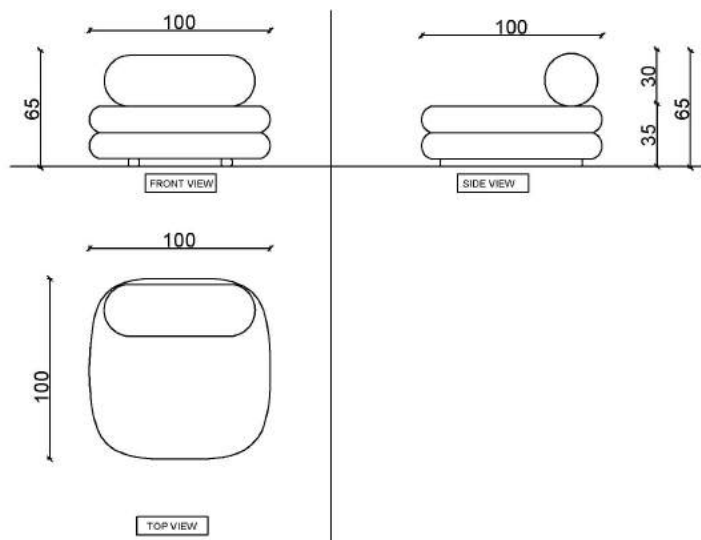

# THE AL FRESCO | Outdoor Sofa

## 6 Modular Elements

3. The Al Fresco Sofa  
Longpouf element 50W x 120L x 35H (CM)

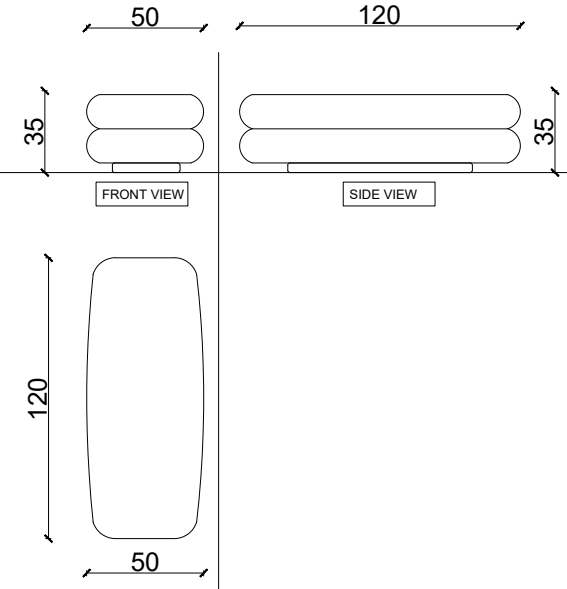

4. The Al Fresco Sofa  
Petitepouf element 50W x 100L x 35H (CM)

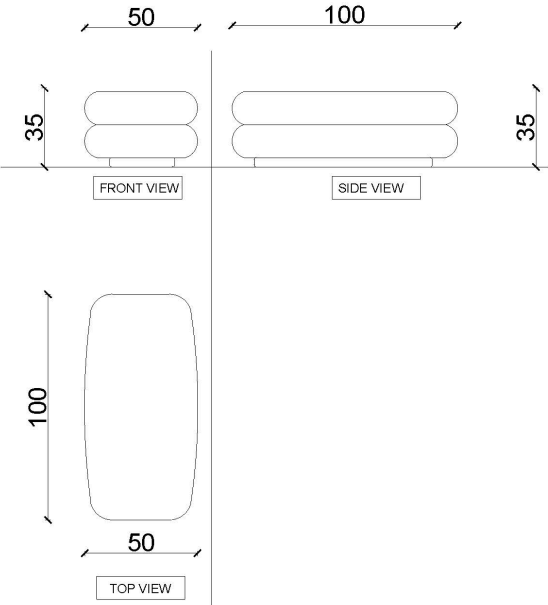

# THE AL FRESCO | Outdoor Sofa

## 6 Modular Elements

5. The Al Fresco Sofa  
 Square pouf element 50W x 50L x 35H (CM)

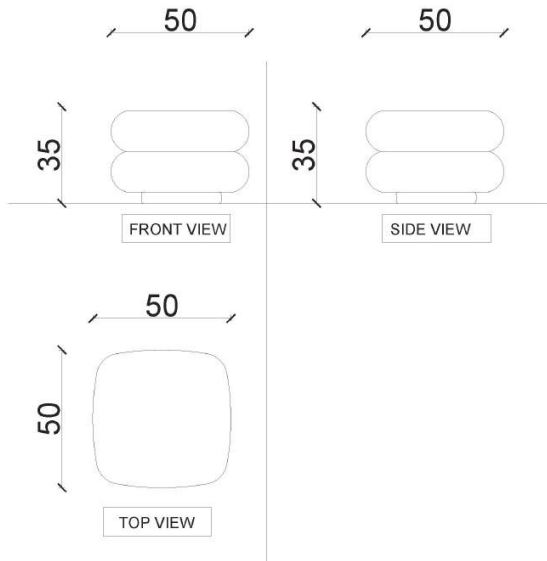

6. The Al Fresco Sofa  
 Duochair element 120W x 100L x 65H (CM)  
 Movable backrest

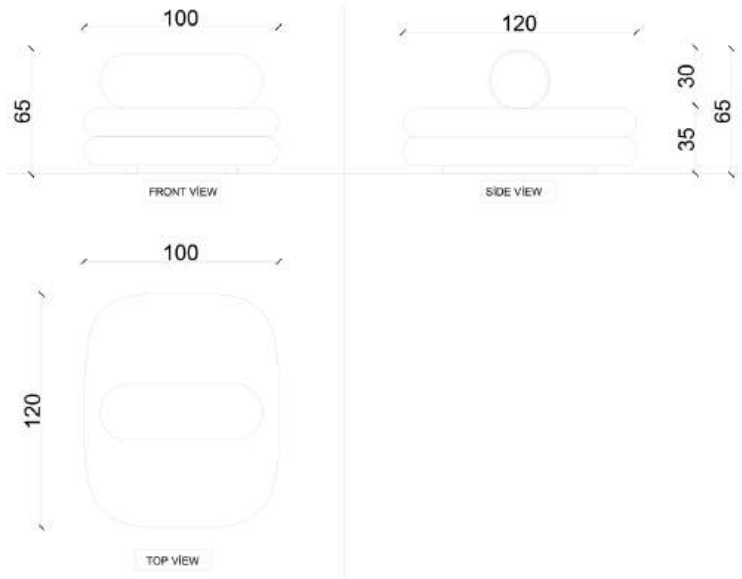

# THE AL FRESCO | Outdoor Sofa Configurations

3 x Petite Element + Square Pouf + Petite Pouf  
Seating fabric: Stripe Harmony Yellow / Backrest fabric: Dune Yellow  
Square pouf fabric: City Yellow / Petite Pouf fabric: Symphony Yellow



2 x Duochair Elements  
Seating fabric: Dune Grey & Starburst Red / Backrest fabric: Starburst B&W



## OUTDOOR SOFA | The Al Fresco Configurations

3 x Petite Element + 3x Square Pouf  
Seating fabric: Stripe Harmony Yellow / Backrest fabric: Dune Yellow  
Square pouf fabric: City Yellow



3 x Duochair Elements  
Seating fabric: Dune Grey & Starburst Red / Backrest fabric: Starburst B&W











# TABLES

---



# MALIBU | Tables

The Malibu Collection features a meticulously crafted travertine top, chosen for its timeless beauty and durability. Travertine, with its subtle variations in color and texture, brings a sense of earthiness and organic charm to the piece. The top is double-layered and designed with rounded edges, creating a soft, inviting appearance while maintaining structural integrity.

The table's legs are where Karine's ingenuity truly shines. The C-leg design, made from travertine, offers stability and a sculptural quality that adds to the table's artistic allure. Complementing this is a wooden leg, which contrasts yet harmonizes with the travertine. The wood is layered meticulously, creating a textured effect that is both visually striking and tactilely pleasing. This layering technique enhances the wood's natural grain and introduces a dynamic element to the table's overall design.

## Choose for table top and C-leg:



Material: Travertine  
Color: Beige



Material: Travertine  
Color: Dark

## Choose for round leg:



Material: Wood  
Color: Dark Walnut



Material: Wood  
Color: Light Oak

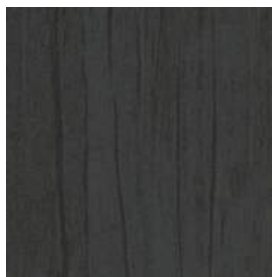

Material: Wood  
Color: Black Oak









# MALIBU | Tables

1. Side Table Malibu  
Dimensions: W50 x L35 x H35 (CM)

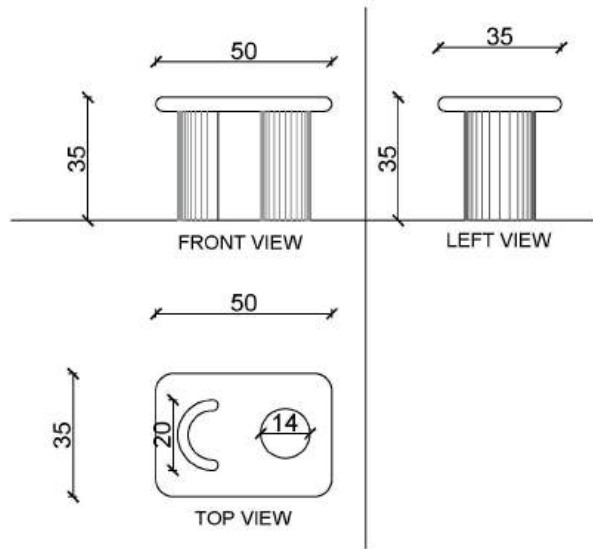

1. Side Table Malibu  
Dimensions: W60 x L45 x H53 (CM)

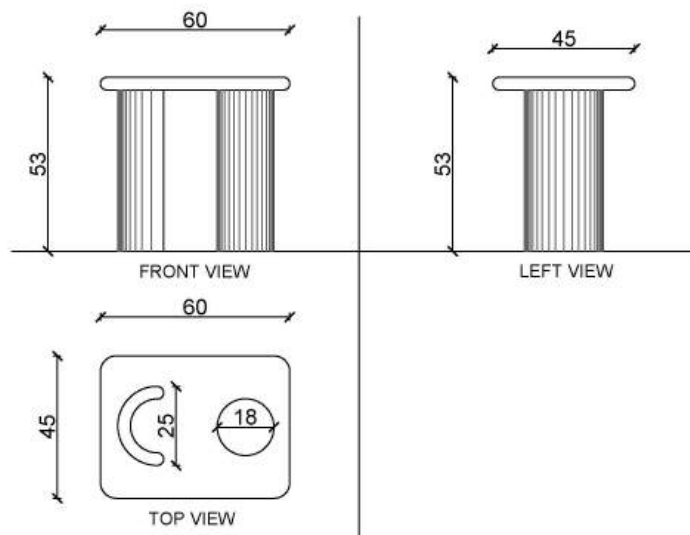

# MALIBU | Tables

3. Side Table Malibu  
Dimensions: W90 x L40 x H44 (CM)

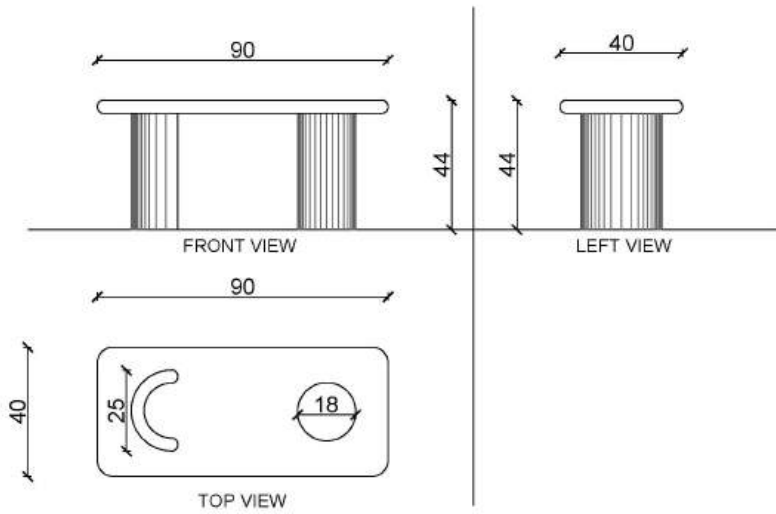

4. Console Table Malibu  
Dimensions: W90 x L60 x H68 (CM)

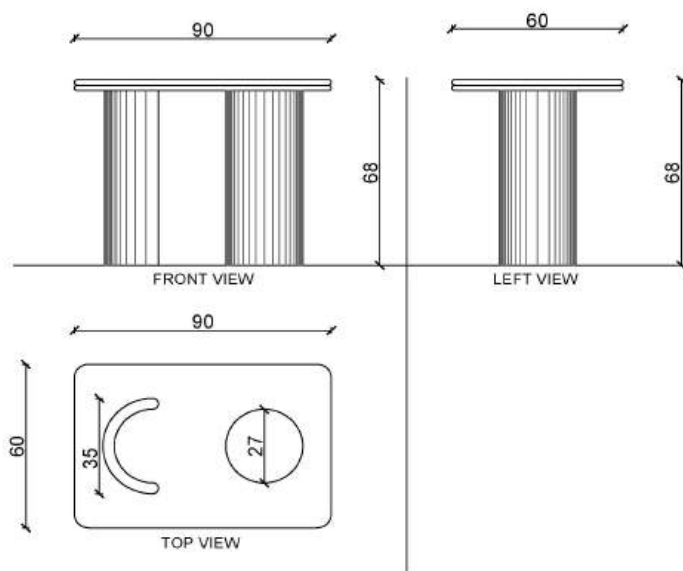

# MALIBU | Tables

5. Dining Table Malibu 200  
Dimensions: W200 x L110 x H76 (CM)

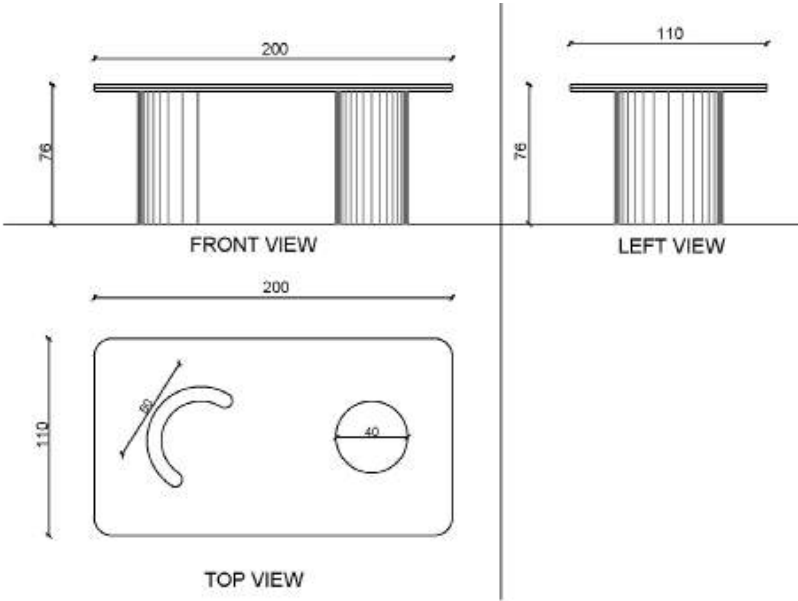

6. Dining Table Malibu 260  
Dimensions: W260 x L110 x H76 (CM)

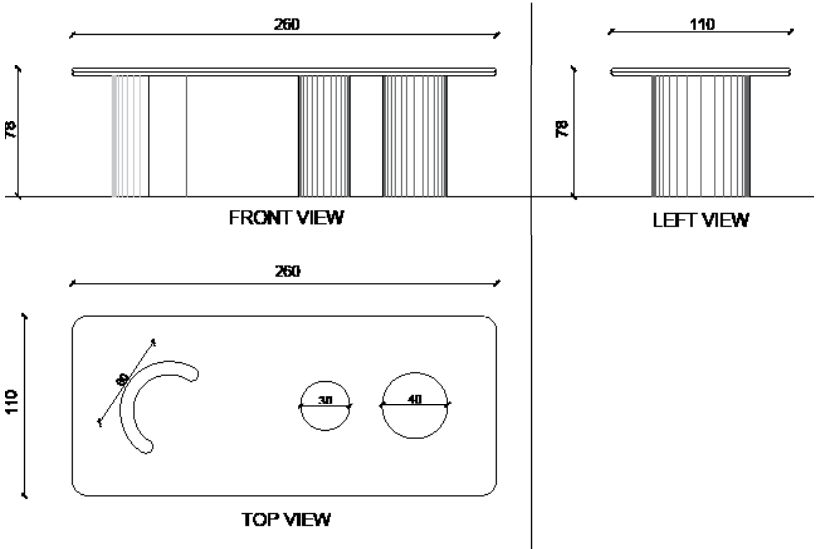







# ONYX | Tables

In the world of interior design, where form often meets function, few pieces manage to embody both attributes with as much grace and simplicity as the Onyx Marble Side Table. This stunning piece is more than just a table; it is a testament to the timeless appeal of minimalist design combined with the opulent beauty of natural materials.

The side table features a top made of massive onyx marble, a material renowned for its striking natural patterns and durability. The onyx marble exudes a sense of luxury and refinement, its smooth, polished surface reflecting light in a way that enhances its unique veining.

The table is designed to be lightweight and easy to move. This makes it an incredibly versatile piece that can be seamlessly integrated into various settings around the home.

Choose for sidetable top:

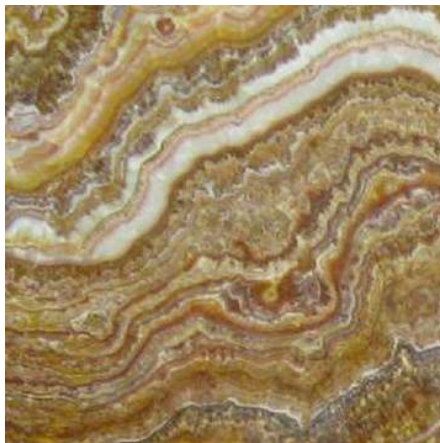

Material: Onyx  
Color: Multicolor



Material: Onyx  
Color: Red

Choose for round base:



Material: Wood/Metal  
Color: Dark Walnut

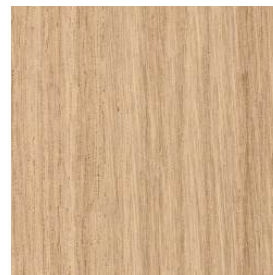

Material: Wood/Metal  
Color: Light Oak

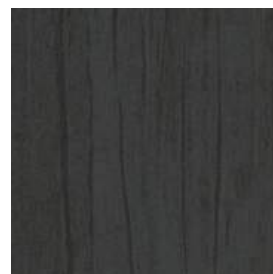

Material: Wood/Metal  
Color: Black Oak





# ONYX | Tables

1. Side Table Onyx  
Dimensions: D33x H45 (CM)

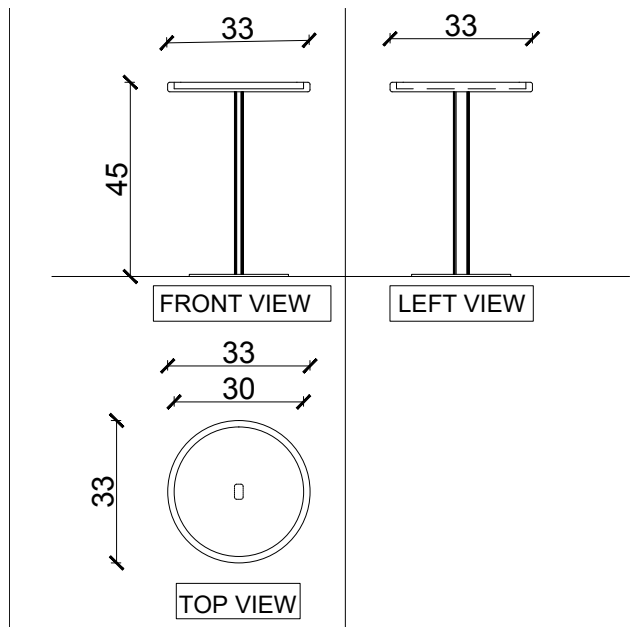



# CHAIRS

---



## GENEVA | Chair

The design begins with a foundation of smooth, polished wooden legs that exude warmth and stability. The rich, natural wood contrasts beautifully with the textured fabric of the seat and backrest, which is available in many different fabrics. These fabrics not only add visual interest but also provides a comfortable and inviting surface for sitting.

The backrest of the chair is particularly noteworthy. Its curved, enveloping form offers both support and a sense of intimacy, inviting users to relax and feel cradled. A piece where ergonomic design meets visual harmony.

Choose for frame:



Material: Wood  
Color: Dark Walnut



Material: Wood  
Color: Light Oak



Material: Wood  
Color: Black Oak



# GENEVA | Chair

1. Chair Geneva  
Dimensions: W59 x L55 x H83 (CM)

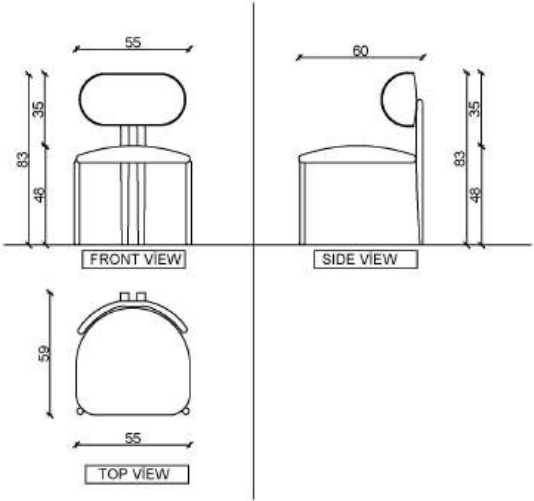





## EMBRACE | Chair

An epitome of mid-century modern design, seamlessly blends form and function, offering both aesthetic pleasure and unparalleled comfort. Crafted from high-quality wood, its frame showcases clean lines and gentle curves that speak to the era's love for organic forms and natural materials.

The chair's silhouette is both elegant and inviting. The backrest, gently curved and upholstered in a textured, creamy fabric, cradles the sitter in comfort, while providing subtle support. This fabric, reminiscent of boucle, adds a tactile contrast to the smooth wooden frame, enhancing the chair's visual appeal.

Choose for frame:



Material: Wood  
Color: Dark Walnut



Material: Wood  
Color: Light Oak



Material: Wood  
Color: Black Oak



# EMBRACE | Chair

1. Chair Geneva  
Dimensions: W59 x L55 x H83 (CM)

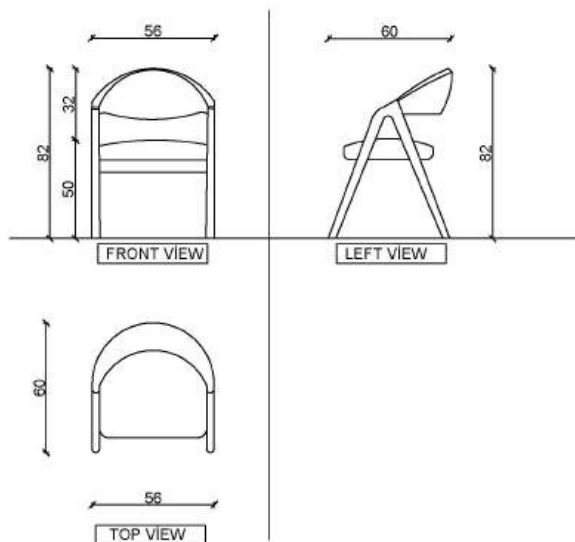

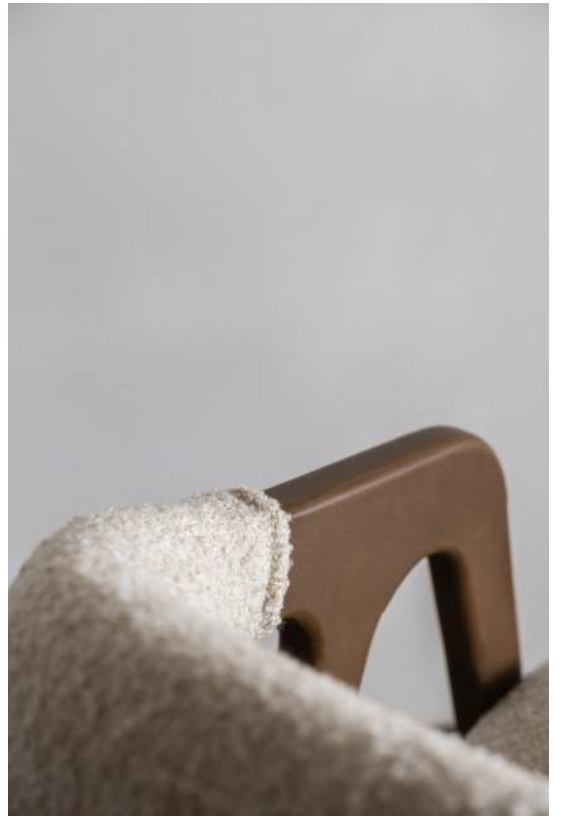





# RUGS

---





## Y | Rug

This exquisite handtufted wool rug, with its innovative dual-layer construction, embodies true quality, offering a sophisticated blend of craftsmanship and design.

The wool, chosen for its durability and luxurious feel, is handtufted into a unique two-layer design. The base layer provides a sturdy foundation, while the upper layer, featuring a striking Y pattern, creates a dynamic visual and tactile contrast. In an era where sustainability is paramount, this rug stands out.

Wool is a renewable resource, and the handtufting process, while labor-intensive, ensures minimal environmental impact. The quality of the craftsmanship means that this rug is built to last, becoming a cherished part of the home for years to come.



# Y | Rugs

1. Rug Y  
Dimensions: Made-To-Measure

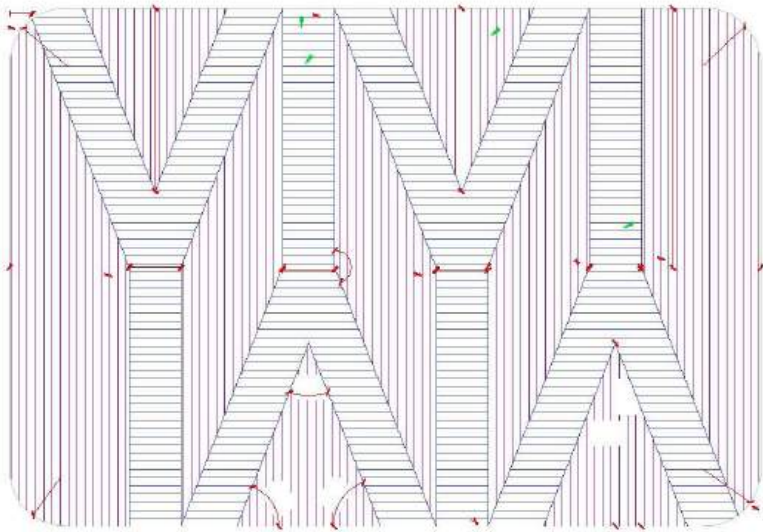

Choose for color rug:



Material: Wool  
Color: Forest Green



Material: Wool  
Color: Latte







# ACCESSORIES





## Box finish 4,5cm thickness | CUSHIONS

Introducing the box cushion from the Everly Collection, a masterpiece of comfort and style designed to elevate any seating arrangement. With its flat board construction at 4.5 cm thickness, this cushion provides a perfect balance of support and plush comfort, making it an ideal addition to both indoor and outdoor settings.

Available in the Everly fabric collection

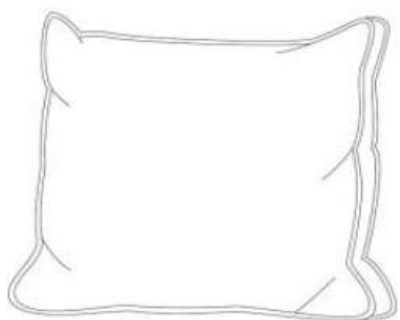



# BLEND & BLOOM

---

Indoor



## THEME SPICE | Blend & Bloom

The Spice Theme draws its inspiration from the rich, diverse hues found in nature's spice palette. These colors evoke feelings of warmth, comfort, and exotic allure, making them perfect for creating inviting and stylish interiors. The incorporation of onyx, with its intricate patterns and natural beauty, ties the entire theme together, highlighting the organic connection between each element.



## THEME BLUE | Blend & Bloom

This thoughtfully curated fabric combination embraces the calming essence of blue hues and complements them with neutral accents, creating a timeless aesthetic that adapts seamlessly to various interior design styles.

The primary fabric, a deep navy with intricate weaving, serves as the foundation, grounding the design with its profound and inviting presence. This is beautifully offset by a lighter blue fabric, featuring a delicate pattern that adds depth and dimension without overpowering the senses.





## THEME MUSTARD | Blend & Bloom

Our "Mustard" theme is a testament to this vision, bringing together the warmth and vibrancy of mustard tones with the calm and timeless appeal of neutral shades.

The Mustard theme features a meticulously curated selection of fabrics and materials. The primary hues of mustard are complemented by a range of neutral tones, creating a harmonious and versatile palette. Each piece in this combination plays a crucial role in achieving the perfect balance between warmth and subtlety.



## THEME GREY | Blend & Bloom

A masterful blend of sophisticated textures and neutral hues, designed to create a serene yet dynamic ambiance in any space. This carefully curated collection features a range of greys, meticulously chosen to complement and enhance each other, with an exquisite onyx piece that ties the theme together with its natural elegance.

The Grey Theme is inspired by the tranquility of natural landscapes, where shades of grey in rocks, pebbles, and cloudy skies create a peaceful and balanced environment. This collection aims to bring that same sense of calm and elegance into interior spaces, making it an ideal choice for modern homes and sophisticated commercial settings.



## THEME FOREST GREEN | Blend & Bloom

The "Forest Green" theme is more than just a color scheme; it is a narrative of nature's elegance and resilience. It draws inspiration from the tranquility of forest landscapes, where every shade of green and every texture plays a part in the grand tapestry of nature.

This design is a celebration of the deep, tranquil hues of the forest, perfectly blended with neutral tones to create a space that is both calming and sophisticated.

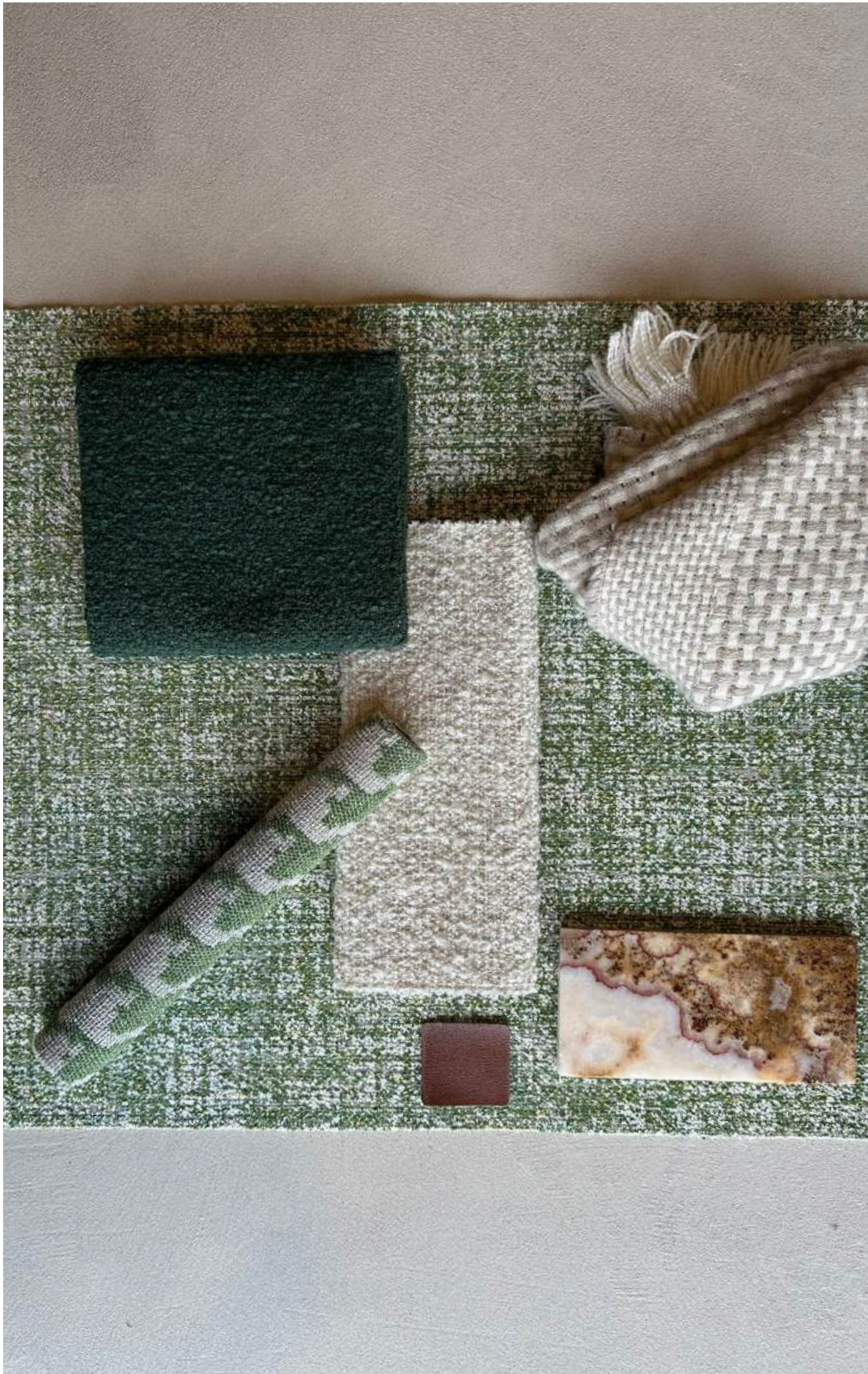

## **THEME SAND | Blend & Bloom**

This theme brings the serene beauty of sand dunes and the earthy tones of nature into your living space, blending sand colors with neutral hues to create a perfect blend & bloom.

The "Sand" theme is designed to create a serene and balanced environment. The careful selection of colors and textures ensures that each piece complements the others, resulting in a harmonious blend that is both visually appealing and soothing to the senses. Whether used in a contemporary living room, a cozy bedroom, or a sophisticated office, the Sand theme brings a touch of nature's elegance into the modern home.





## THEME CREAM | Blend & Bloom

The "Cream" theme, embodies this philosophy with a delicate balance of cream tones and neutral hues, accentuated by a stunning onyx piece that ties the ensemble together.

The Cream theme is a symphony of soft, inviting shades that evoke a sense of calm and sophistication. Each fabric in this collection has been meticulously chosen to create a seamless blend. The primary focus on cream tones provides a serene foundation, while the neutral elements add depth and versatility.



## THEME BROWN | Blend & Bloom

Karine's inspiration came from the natural elegance of moonstones, their soft glow and smooth curves mirrored in the design. She envisioned a sofa that exuded a sense of tranquility and sophistication, much like the gemstone itself. The plissé fabric was chosen for its textured beauty and ability to create soft, flowing lines, adding a tactile dimension to the design.

The Moonstone sofa would be as good as only foam structure, eliminating the need for wood and reducing its environmental footprint.

"I wanted to create something unique, a piece that stands out yet feels inviting and adaptable."



## THEME MINT GREEN | Blend & Bloom

Karine's inspiration came from the natural elegance of moonstones, their soft glow and smooth curves mirrored in the design. She envisioned a sofa that exuded a sense of tranquility and sophistication, much like the gemstone itself. The plissé fabric was chosen for its textured beauty and ability to create soft, flowing lines, adding a tactile dimension to the design.

The Moonstone sofa would be as good as only foam structure, eliminating the need for wood and reducing its environmental footprint.

"I wanted to create something unique, a piece that stands out yet feels inviting and adaptable."

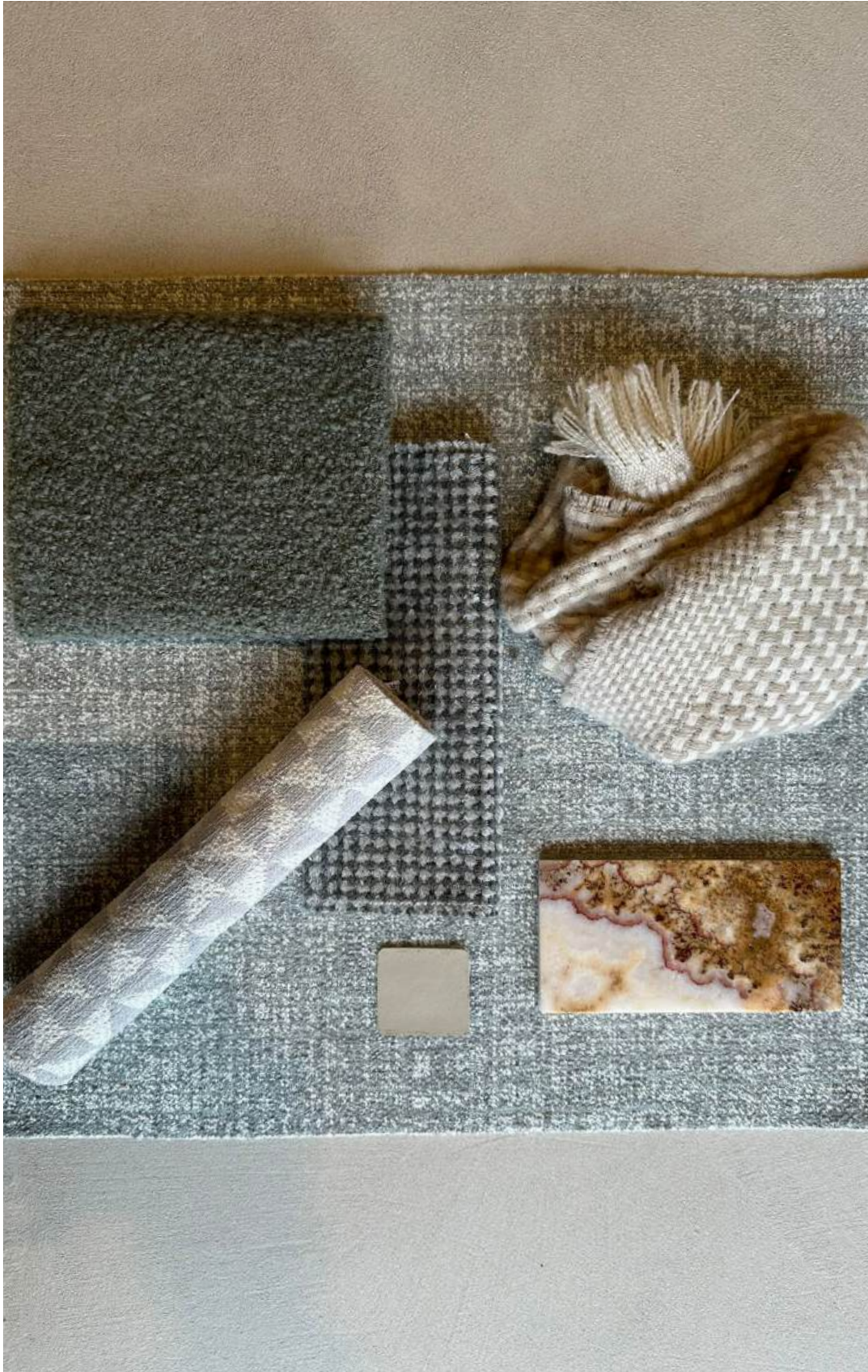

**BLEND & BLOOM**

---

**Outdoor**





## OUTDOOR THEME GREY | Blend & Bloom

Inspired by the serene beauty of outdoor landscapes and the robust strength of nature, this collection of outdoor fabrics embodies a harmonious blend of aesthetic appeal and high-performance durability. Designed to withstand the elements, these fabrics combine water resistance with lightfastness, ensuring they maintain their beauty and functionality in any outdoor setting.

The neutral tones of grey featured in this collection are carefully curated to complement any outdoor environment, from urban terraces to garden patios. The sophisticated shades of grey provide a versatile backdrop that blends seamlessly with various natural surroundings while adding a touch of modern elegance.



## OUTDOOR THEME YELLOW | Blend & Bloom

Inspired by the serene beauty of outdoor landscapes and the robust strength of nature, this collection of outdoor fabrics embodies a harmonious blend of aesthetic appeal and high-performance durability. Designed to withstand the elements, these fabrics combine water resistance with lightfastness, ensuring they maintain their beauty and functionality in any outdoor setting.

The palette centers around shades of yellow, ranging from soft, sun-bleached tones to richer, golden hues. These colors evoke a sense of warmth and happiness, making your outdoor areas feel inviting and alive. The yellows are versatile, easily pairing with natural elements like wood and greenery, and enhancing the beauty of any outdoor setting.



## OUTDOOR THEME BLUE | Blend & Bloom

Inspired by the tranquil beauty of the ocean and the endless skies, this collection of outdoor fabrics brings a sense of serenity and elegance to any outdoor space. Designed with high durability and water resistance, these fabrics are perfect for creating a stylish and comfortable outdoor retreat. The rich blue tones and diverse patterns evoke a sense of calm and sophistication, reminiscent of coastal living.

The collection is dominated by various shades of blue, from deep navy to soft sky blue. These colors are chosen to reflect the natural hues of the sea and sky, creating a cohesive and calming atmosphere. The blues are versatile and timeless, easily blending with different outdoor settings and decor styles.

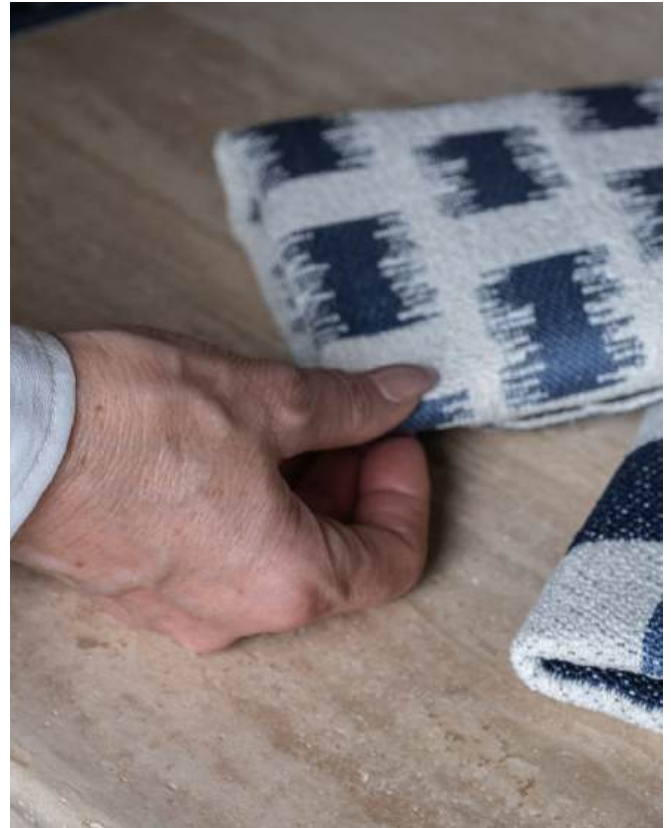

## OUTDOOR THEME RED | Blend & Bloom

This collection of outdoor fabrics is inspired by the warmth and richness of earthy reds, evoking the cozy charm of rustic landscapes and the vibrant energy of sunsets. These fabrics are designed to bring a sense of warmth and comfort to your outdoor spaces, combining aesthetic appeal with high-performance durability. Resistant to water and fading, they ensure your outdoor decor remains beautiful and functional through all seasons.

The palette features a range of red tones, from deep terracotta to soft clay hues. These colors reflect the natural beauty of the earth and create a welcoming, cozy atmosphere. The reds are versatile and can easily complement a variety of outdoor settings, adding a touch of rustic elegance.



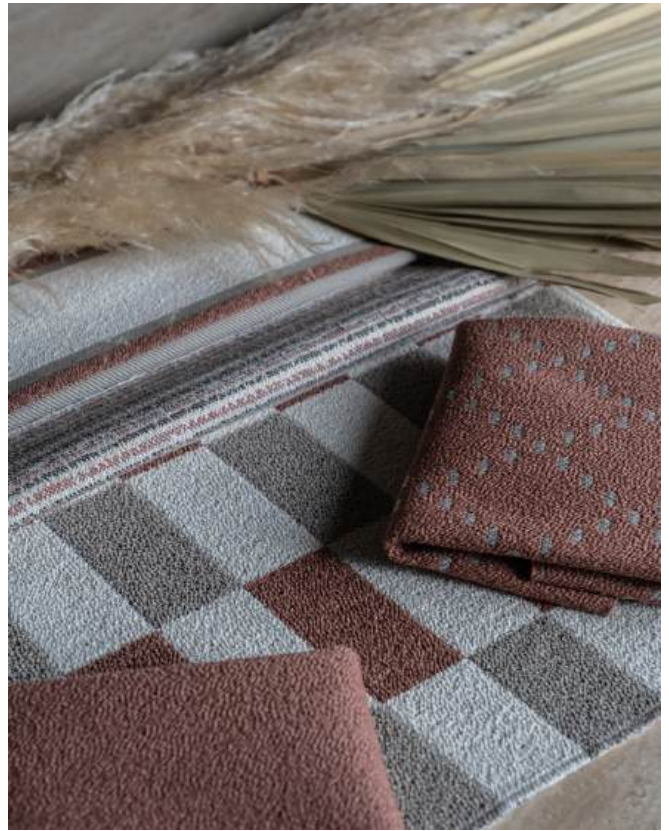

## OUTDOOR THEME B&W | Blend & Bloom

This collection of outdoor fabrics embodies the classic sophistication of black and white. Inspired by the timeless appeal of monochrome palettes, these fabrics bring a refined elegance to any outdoor space. Designed for durability and practicality, they offer water resistance and lightfastness, ensuring that their striking patterns remain beautiful and functional through all seasons.

The palette is a monochrome symphony of black, white, and shades of grey. These neutral tones are versatile and sophisticated, providing a sleek, modern look that complements any outdoor setting. The black and white theme is both classic and contemporary, making it a perfect choice for those seeking elegance and simplicity.

